

A fully automated, multistep flow synthesis of 5-amino-4-cyano-1,2,3-triazoles†

Catherine J. Smith, Nikzad Nikbin, Steven V. Ley, Heiko Lange and Ian R. Baxendale

Received 1st October 2010, Accepted 22nd November 2010

DOI: 10.1039/c0ob00815j

Having demonstrated in the preceding publication the flow synthesis of aryl azides, we describe here a general protocol for the in-line purification of these versatile intermediates. As part of this investigation, we evaluated the use of ReactIR 45m as a tool for real-time detection of hazardous azide contaminants. This azide synthesis and purification process was then incorporated into a multistep flow sequence to generate a small collection of 5-amino-4-cyano-1,2,3-triazoles directly from aniline starting materials in a fully automated fashion.

Introduction

Following the successful application of aryl azides in the Staudinger aza-Wittig reaction,¹ we were interested in exploring other uses of these valuable building blocks in multistep flow processes. Although we were able to make use of a convenient catch-react-and-release purification in the flow Staudinger procedure, we were aware that other potential sequences employing aryl azides might not lend themselves to this method of purification. Given that the preparation of aryl azides involves the use of toxic anilines and trimethylsilyl azide, it was of critical importance not only for product purity but also for process safety to remove any unreacted starting materials from the flow stream before isolation or further use. We describe here the development of a general purification protocol that enables the generation and purification of aryl azides within a contained flow system, providing safe and efficient access to clean aryl azides as intermediates or final products.

With pure aryl azides in hand, one can envision a wide range of possible derivatisation reactions which can be applied to these versatile intermediates.² Building on previous work with similar scaffolds,³ we were particularly interested in designing a multistep flow route for the synthesis of the biologically interesting 5-amino-4-cyano-1,2,3-triazole templates generated by the reaction of aryl azides with malononitrile.⁴

As discussed in the preceding publication, safety, product purity and efficiency – in terms of chemist and laboratory time as well as materials – are high priorities for the design of flow synthesis routes.⁵ In order to address the efficiency aspect, we set out to explore further options for the automation of complex multistep

flow processes,⁶ with the goal of enabling 24/7 operation by carrying out multiple sequential reactions in a fully automated fashion. Here we report on the use of Gilson Trilution LC and/or Unipoint software⁷ to successfully automate the flow preparation of a small collection of 5-amino-4-cyano-1,2,3-triazoles from simple aniline starting materials.

Results and discussion

Purification of aryl azides in flow

While the flow method for aryl azide generation described in the preceding publication generally provides aryl azides in high conversion from the corresponding anilines, the desired azide products are potentially contaminated with unreacted trimethylsilyl azide (which is readily hydrolysed to toxic, volatile and explosive hydrazoic acid) and aniline starting materials. When these aryl azides were carried on directly to the Staudinger reaction in flow,¹ these contaminants could be washed to waste and collected for immediate destruction or disposal. If aryl azides are to be carried on to further reactions that do not provide this convenient purification step, however, the benefits of generating aryl azides in flow are greatly diminished by having to carry toxic materials through with the desired product. In this case, contamination with unreacted starting material is not only a concern with respect to product purity, but presents an unacceptable situation in terms of process safety.

Therefore, we have developed a scavenging protocol by which the aryl azide stream can be purified in-line using readily available and inexpensive scavenger resins, greatly improving both product purity and process safety. As shown in Scheme 1, following azide synthesis (1 mmol scale), the reaction stream passes through a 10 mm i.d. × 8 cm height glass column containing 1.3 g of polymer-supported sulfonic acid (QP-SA), followed by 1.3 g of polymer-supported dimethylamine (QP-DMA). The QP-SA traps

Innovative Technology Centre, Department of Chemistry, University of Cambridge, Lensfield Road, Cambridge, UK CB2 1EW. E-mail: theitc@ch.cam.ac.uk

† Electronic supplementary information (ESI) available. CCDC reference numbers 791579, 791580, 791582, 791583. For ESI and crystallographic data in CIF or other electronic format see DOI: 10.1039/c0ob00815j

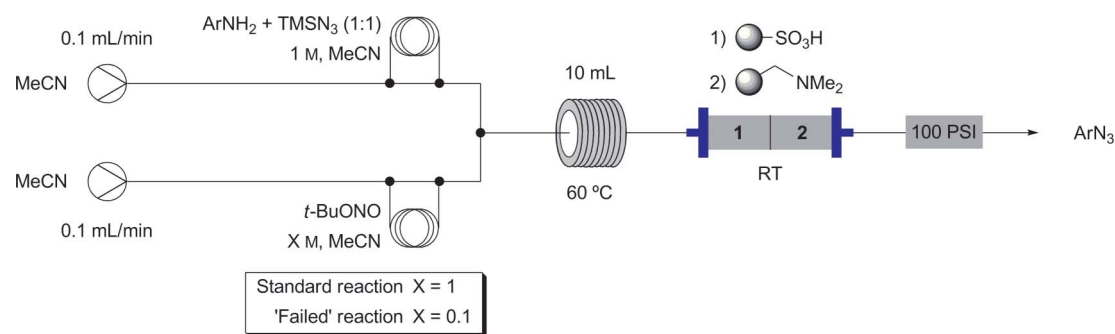

Scheme 1 Synthesis and purification of aryl azides in flow. *Inset:* Used scavenging column containing QP-SA (left) and QP-DMA (right) with discolouration indicative of scavenged impurities.

any unreacted aniline whilst at the same time converting any remaining trimethylsilyl azide to hydrazoic acid, which is in turn trapped onto the QP-DMA.

Since this scavenging step is necessary for both purity and safety, it was important to ensure that enough scavenger was used to completely remove the undesired contaminants. Although all of the azide syntheses investigated proceeded with at least 80% conversion, this scavenging protocol was tested for its effectiveness in both a successful reaction and a hypothetical worst-case scenario in which only a 10% reaction had occurred. This 'failed' reaction was simulated by carrying out the azide synthesis with only 0.1 equivalent of *tert*-butyl nitrite, resulting in a maximum 10% conversion and requiring the scavengers to remove the remaining 90% of unreacted starting aniline and trimethylsilyl azide.

The scavenging protocol was evaluated by monitoring the reaction output for the presence of azide or aniline contaminants in standard and failed reactions with and without scavenging. Residual aniline starting material was detected by ^1H NMR analysis of the crude output stream (no evaporation). Residual hydrazoic acid or trimethylsilyl azide was detected by colourimetric evaluation of the output stream at periodic intervals using a ferric chloride indicator.⁸

The substrate 3,5-bis(trifluoromethyl)aniline was chosen for these control reactions, as the colours of both the aniline starting material and aryl azide product would not interfere with the colourimetric analysis. As shown in Fig. 1, it was possible to clearly detect the presence of trimethylsilyl azide in MeCN by visual inspection down to a concentration of 0.005 M, and it was confirmed that none of the reaction components either gave a false positive or interfered with the detection of trimethylsilyl azide in a positive control sample. Consequently, flow reactions were carried out as described above (Scheme 1), with a sample of the output stream being tested with the ferric chloride assay every two minutes. The total combined reaction output was also collected and examined by ^1H NMR.

As shown in Table 1, both the successful and failed reactions without scavenging contained residual aniline and azide starting materials. However, colourimetric testing and ^1H NMR analysis confirmed that, within the limits of detection, azide synthesis followed by in-line scavenging (Scheme 1) yields an output stream free from aniline, trimethylsilyl azide or hydrazoic acid, even in the case of a failed reaction with less than 10% conversion to the desired product.

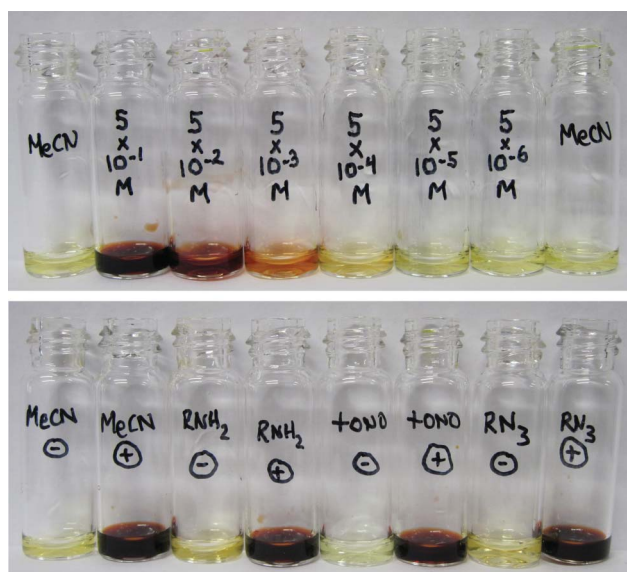

Fig. 1 Ferric chloride controls. *Top:* Concentration screen of trimethylsilyl azide in MeCN; a positive result (red colour) is clearly visible down to 0.005 M. *Bottom:* Starting materials and product for test reactions; negative control vials (-) contain only the reaction component (0.5 M in MeCN), positive control vials (+) contain the reaction component and trimethylsilyl azide (1 : 1, 0.5 M in MeCN).

Evaluation of in-line monitoring of trimethylsilyl azide

While colourimetric testing provides a reliable off-line method for detection of trimethylsilyl azide or hydrazoic acid, an in-line monitoring technique would allow real-time detection⁹ of these undesired materials within a multistep flow synthesis, without exposure to potentially contaminated reaction streams. We therefore evaluated the potential of monitoring for residual trimethylsilyl azide or hydrazoic acid using the ReactIR flow cell recently developed by Mettler-Toledo.^{10,11} The original diamond (DiComp)

Table 1 Evaluation of scavenging procedure by ^1H NMR and FeCl_3

Test reaction (RNH_2 : TMSN_3 : <i>t</i> -BuONO)	Scavenge	^1H NMR (Aniline : Azide)	FeCl_3
Standard (1 : 1 : 1)	No	12 : 88	+
Standard (1 : 1 : 1)	Yes	Azide only	-
Failed (1 : 1 : 0.1)	No	92 : 8	+
Failed (1 : 1 : 0.1)	Yes	Azide only	-

sensor for this equipment was not ideal for the monitoring of azide species due to the inherent ‘blind spot’ of the diamond sensor (2250–1950 cm^{-1}). This allows only weak absorbance in the region of the normally strong azide $\text{N}=\text{N}=\text{N}$ asymmetric stretching bands ($\nu = 2160\text{--}2120\text{ cm}^{-1}$). We report here upon the evaluation of a prototype silicon (SiComp) sensor, which does not suffer from this blind spot, for the in-line detection of trimethylsilyl azide or hydrazoic acid. As shown in Fig. 2, the sensitivity in the azide

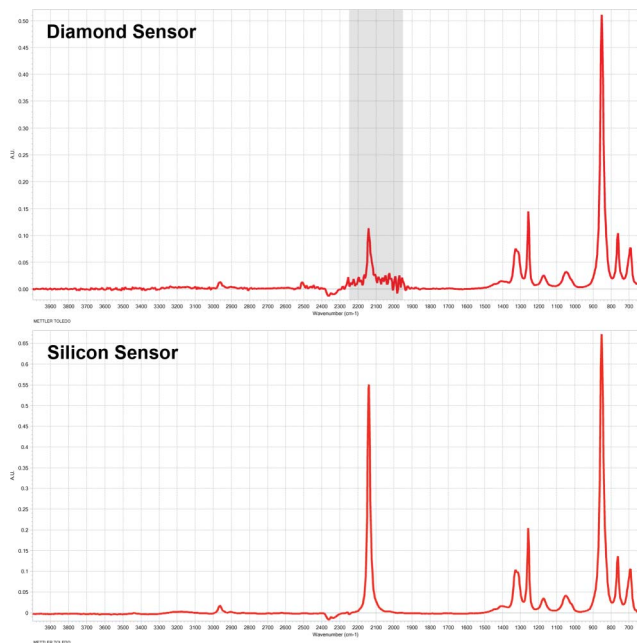

Fig. 2 IR spectrum (4000–650 cm^{-1}) of trimethylsilyl azide (0.5 M in MeCN) using the ReactIR. *Top*: Diamond sensor, with grey box indicating the diamond ‘blind spot’ (2250–1950 cm^{-1}). *Bottom*: Silicon sensor.

$\text{N}=\text{N}=\text{N}$ asymmetric stretching region is much improved for the silicon (Fig. 2, bottom) over the original diamond sensor (Fig. 2, top).¹²

We carried out a calibration of the detector using varying concentrations of trimethylsilyl azide in acetonitrile. As shown in Fig. 3, the strong $\text{N}=\text{N}=\text{N}$ asymmetric stretching band of trimethylsilyl azide ($\nu = 2141\text{ cm}^{-1}$) could be clearly detected at concentrations of 0.05 M or greater. Therefore, the detection limits of the device would require improvement in order to comfortably rely on ReactIR as a replacement for the established off-line colourimetric test to confirm complete azide removal. We were still interested, however, in evaluating this device as a tool to provide real-time information about reaction and scavenging processes within the range of its current sensitivity.

We began by monitoring the simple test case of scavenging trimethylsilyl azide in isolation. A 0.5 M solution of trimethylsilyl azide in acetonitrile was pumped at 0.2 mL min^{-1} through a column packed with either QP-SA or QP-DMA independently, or through both reagents in series, and the output monitored by both ReactIR and the ferric chloride assay. Fig. 4 shows an overlay of the IR spectrum at the most concentrated point in the reaction plug for each run, along with a reference spectrum of trimethylsilyl azide at 0.5 M. In each case there was agreement between the ferric chloride test and the ability to detect a $\text{N}=\text{N}=\text{N}$ band in the IR spectrum. Passage of trimethylsilyl azide through either QP-DMA or QP-SA alone resulted in the detection of an azide species by both IR and ferric chloride. However, no residual azide was detected by either method after passage through a combined QP-SA/QP-DMA scavenging column.

In order to provide useful information about real reactions and scavenging processes, it is necessary for the ReactIR to be able to detect trimethylsilyl azide or hydrazoic acid in the presence of other reaction components, including the azide

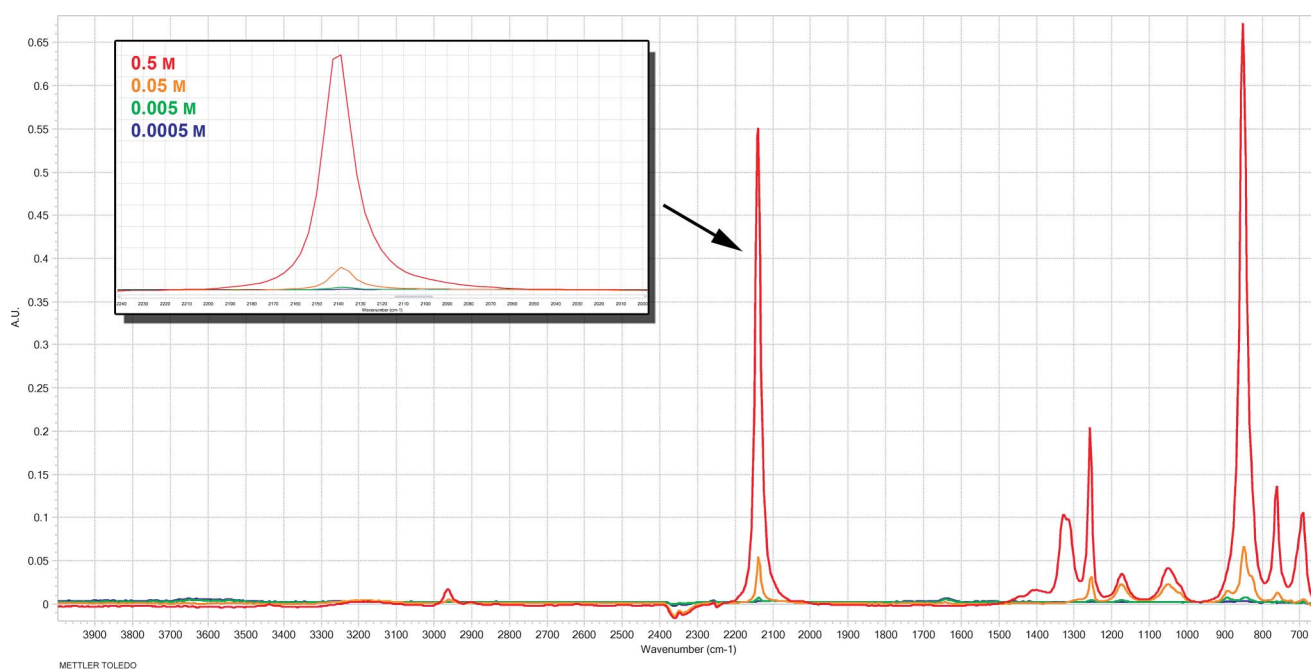

Fig. 3 IR spectra (4000–650 cm^{-1}) using the ReactIR silicon sensor for a concentration screen of trimethylsilyl azide in MeCN. Red line = 0.5 M, orange line = 0.05 M, green line = 0.005 M, blue line = 0.0005 M. *Inset*: Zoom of the azide $\text{N}=\text{N}=\text{N}$ asymmetric stretching region (2240–2000 cm^{-1}). The strong $\text{N}=\text{N}=\text{N}$ asymmetric stretching band of trimethylsilyl azide ($\nu = 2141\text{ cm}^{-1}$) is clearly visible at concentrations of 0.05 M or greater.

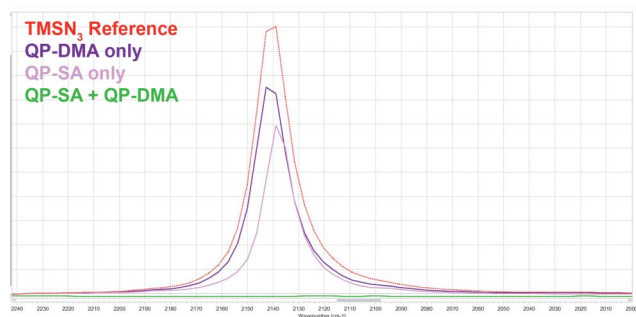

Fig. 4 IR spectra for trimethylsilyl azide scavenging tests, zoomed into the azide N=N=N asymmetric stretching region (2240–2000 cm^{-1}). Red dotted line = trimethylsilyl azide reference, dark purple solid line = QP-DMA only, light purple solid line = QP-SA only, green solid line = scavenging with both QP-SA and QP-DMA.

product. We therefore returned to the synthesis of 1-azido-3,5-bis(trifluoromethyl)benzene and repeated the control reactions described in Table 1, with the ReactIR cell incorporated just prior to the exit of the flow system. The ReactIR results were validated by comparison with ferric chloride testing and ^1H NMR analysis of the output as previously outlined. Fig. 5 shows the IR reference spectra of the starting materials and 1-azido-3,5-bis(trifluoromethyl)benzene product. As shown in Fig. 5 (inset), the detection of undesired trimethylsilyl azide or hydrazoic acid contaminants by ReactIR may be complicated by the presence and potential overlap of the N=N=N asymmetric stretching band for the aryl azide product (in this case, $\nu = 2122 \text{ cm}^{-1}$).

Fig. 6 shows the ReactIR results, as well as the ^1H NMR and ferric chloride test results for the standard (left) and failed (right)

synthesis of 1-azido-3,5-bis(trifluoromethyl)benzene. ReactIR results are again presented as an overlay of the IR spectrum at the most concentrated point in the reaction plug for each run, along with reference spectra of trimethylsilyl azide (Fig. 6, red dotted lines) and 1-azido-3,5-bis(trifluoromethyl)benzene (Fig. 6, blue dotted lines). In agreement with our previous control reactions, no undesired azide species were detected by either ferric chloride testing or ReactIR in the reactions with in-line scavenging (Fig. 6, solid green lines). The solid purple lines in Fig. 6 represent the test reactions without scavenging. In the standard reaction without scavenging (Fig. 6, left, purple line), the small amount of residual trimethylsilyl azide was detected by the ferric chloride test, but was not visible in the IR spectrum. In the corresponding failed reaction, however, the unreacted trimethylsilyl azide can be clearly detected in the IR spectrum (Fig. 6, right, purple line).

As demonstrated by these control reactions, the ReactIR cannot yet compete with off-line colourimetric testing for reliable detection of small amounts of trimethylsilyl azide in reaction streams. However, the ReactIR can provide important information in terms of safety in the flow synthesis of aryl azides by enabling early in-line detection of critical process failure.

Synthesis of 5-amino-4-cyano-1,2,3-triazoles

With access to a flow stream of pure aryl azide, we investigated the further reaction of these azide intermediates to generate a small collection of 5-amino-4-cyano-1,2,3-triazoles (Scheme 2) in flow.⁴

A seemingly straightforward method for the combination of this azide stream with the base and malononitrile would be to introduce these components in a third flow stream. However, working in segmented flow presents a technical challenge in terms

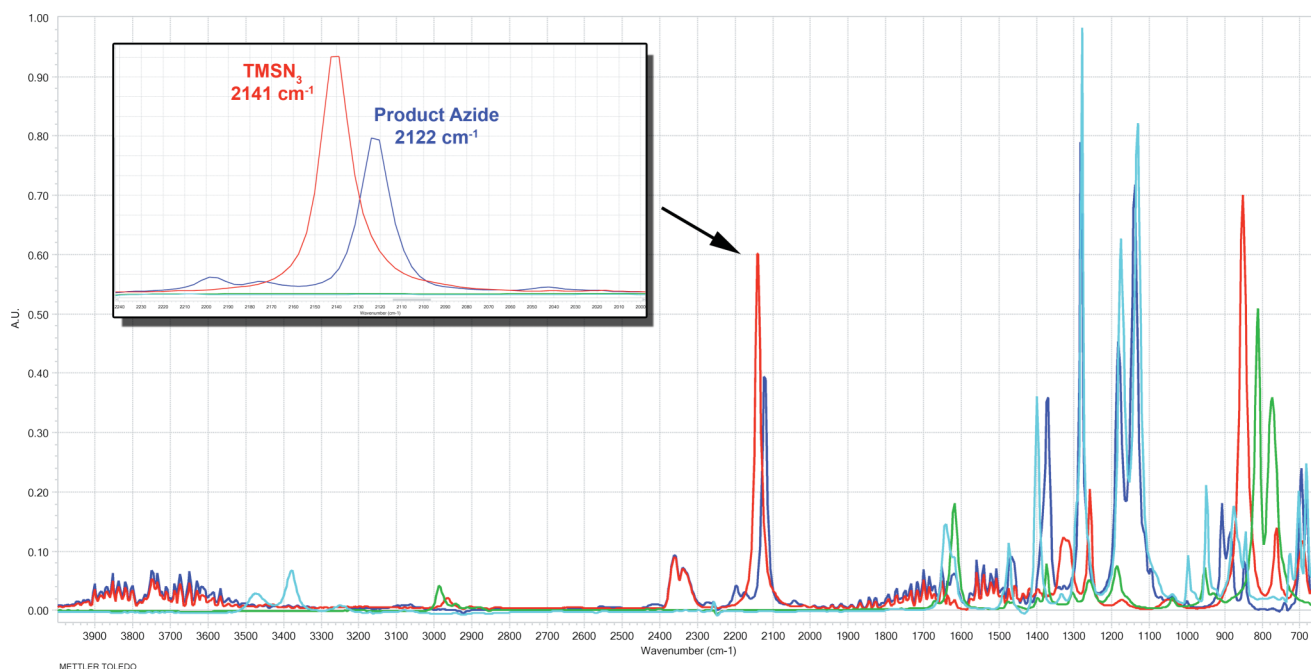
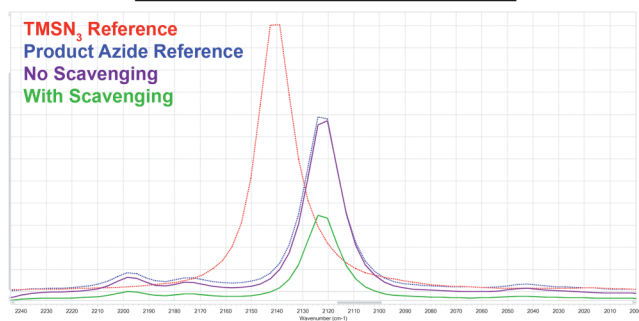

Fig. 5 Reference IR spectra (4000–650 cm^{-1}) for the starting materials and product for scavenging test reactions. Dark blue line = 1-azido-3,5-bis(trifluoromethyl)benzene product, red line = trimethylsilyl azide starting material, light blue line = 3,5-bis(trifluoromethyl)aniline starting material, green line = *tert*-butyl nitrite starting material; each 0.5 M in MeCN. Inset: Zoom of the azide N=N=N asymmetric stretching region (2240–2000 cm^{-1}).

Scavenging Tests: Standard Reaction



Test Reaction (RNH ₂ :TMSN ₃ : <i>t</i> -BuONO)	Scavenge	¹ H NMR (Aniline : Azide)	FeCl ₃
Standard (1:1:1)	No	13 : 87	+
Standard (1:1:1)	Yes	Azide only	-

Scavenging Tests: Failed Reaction

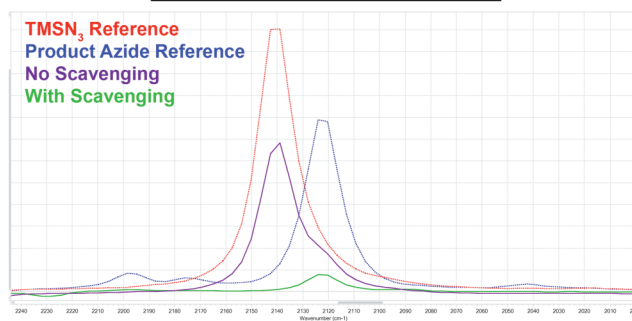

Test Reaction (RNH ₂ :TMSN ₃ : <i>t</i> -BuONO)	Scavenge	¹ H NMR (Aniline : Azide)	FeCl ₃
Failed (1:1:0.1)	No	91 : 9	+
Failed (1:1:0.1)	Yes	Azide only	-

Fig. 6 Evaluation of ReactIR monitoring for trimethylsilyl azide scavenging in the flow synthesis of 1-azido-3,5-bis(trifluoromethyl)benzene. Presented here are ReactIR, ¹H NMR and ferric chloride test results for these control reactions. IR spectra (2240–2000 cm⁻¹) are representative spectra for the flow reactions with (green solid line) and without (purple solid line) scavenging, overlaid with reference spectra for trimethylsilyl azide (red dotted line) and 1-azido-3,5-bis(trifluoromethyl)benzene (blue dotted line). *Left*: Standard reaction with (green) and without (purple) scavenging. *Right*: Failed reaction with (green) and without (purple) scavenging.

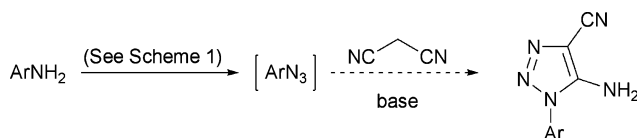

Scheme 2 General preparation of 5-amino-4-cyano-1,2,3-triazoles.

of the introduction of a third stream of reagents with consistent stoichiometry relative to the *in situ* generated intermediate.¹ In this case, the azide intermediate exits the scavenging column as a disperse plug with an unknown and varying concentration profile. Without the ability to precisely monitor this output and effect the corresponding delivery of the malononitrile/base stream, it is a more attractive strategy to introduce them in an immobilised form.

Immobilisation of malononitrile

We planned to effect conversion to the desired triazole products by directing the stream of azide intermediate through a column of malononitrile, immobilised as its corresponding anion on polymeric support. This would also enable the use of an excess of malononitrile and base without contamination of the resulting product stream.

The malononitrile reaction column was thus generated using Ambersep 900 (A900) hydroxide form resin. Resin loading was carried out in THF, as co-workers in our laboratory had previously found A900 hydroxide resin to cause the hydrolysis of acetonitrile to acetamide. A 15 mm i.d. glass column was packed to 3 cm height with a slurry of A900 hydroxide resin in ethanol. This column was then washed with dry THF at 1 mL min⁻¹ for 20 min, causing the resin to shrink. The column plunger ends were adjusted to approximately 1.5 cm height and the column was then loaded by washing with excess malononitrile (10 mmol, 1 M in dry THF) at a flow rate of 1 mL min⁻¹. The resulting malononitrile column was washed at 1 mL min⁻¹ with dry THF to remove excess malononitrile and residual water before switching to MeCN for use

in the triazole synthesis. It was found that the loaded malononitrile column could be stored in a sealed column in THF on the benchtop for up to 6 weeks prior to use, indicating the potential for this toxic material to be supplied as pre-loaded cartridges of ready to use immobilised reagent.

The loading of the final malononitrile resin was difficult to quantify because the A900 hydroxide resin is supplied water wet, however, this procedure consistently resulted in a loading of 4–5 mmol of captured malononitrile per column, based on the amount of recovered malononitrile. As described below, these columns were sufficient to effect full conversion of various aryl azides to the desired triazole products on 1 mmol scale.

Synthesis of 5-amino-4-cyano-1,2,3-triazoles in flow

Azide synthesis and purification was carried out using the general procedure shown in Scheme 1. The pure azide stream was then passed directly through a column of supported anionic malononitrile before exiting the flow system as shown in Scheme 3 (Step 1 only). Early optimisation studies indicated that for some substrates, the reactions did not proceed to completion at room temperature. Carrying out the triazole synthesis step at 60 °C by heating the malononitrile reaction column in the R4 convection heater resulted in full conversion for a wide range of substrates.

While some of the desired product was obtained by simply washing the malononitrile reaction column with acetonitrile following the reaction, low mass returns indicated that the triazole product was being retained as the corresponding anion in the malononitrile reaction column.¹³ A variety of proton sources were evaluated for the release of the desired product. The most effective reagent for clean release of the desired triazole products was found to be malononitrile itself (Scheme 3, Step 2). This did result in mixed stream of the desired products with malononitrile, however with the base component immobilised, this excess malononitrile could be safely and easily removed from the desired products by evaporation within a contained system using a GeneVac evaporator (HPLC setting, 60 °C). This release protocol had

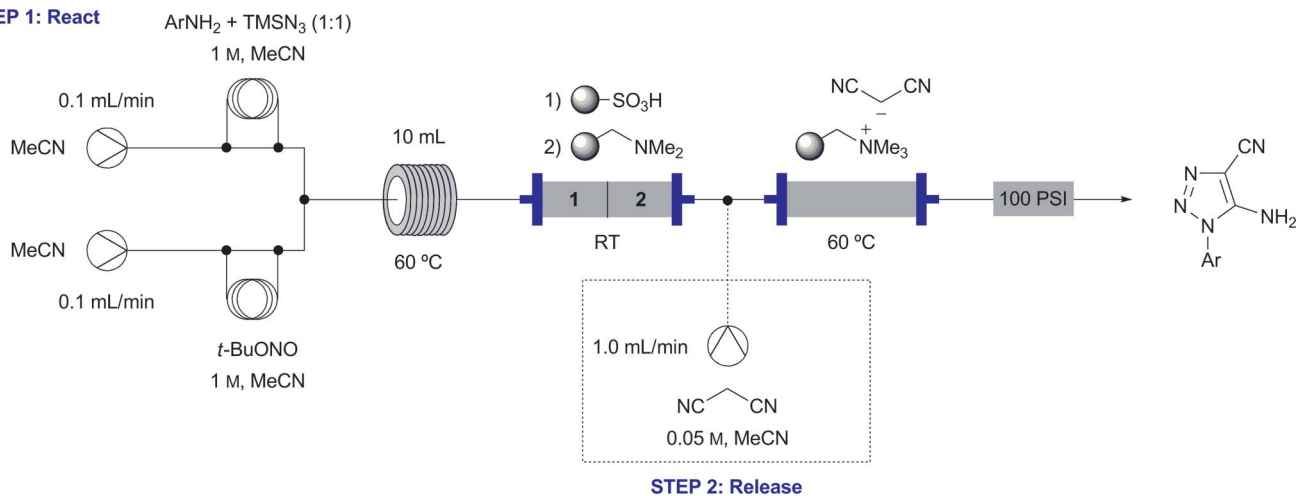
STEP 1: React

Scheme 3 Flow synthesis of 5-amino-4-cyano-1,2,3-triazoles.

the additional benefit of regenerating the reaction column, which could be successfully reused for at least six consecutive reactions.¹⁴

A collection of 5-amino-4-cyano-1,2,3-triazoles were thus generated in flow from aniline starting materials as shown in Scheme 4, with the triazole products being purified simply by evaporation of solvent and malononitrile. Final products were obtained in $\geq 90\%$ purity as determined by ¹H NMR.

Fully automated library synthesis of 5-amino-4-cyano-1,2,3-triazoles in flow

Ideally, automation of flow processes should increase process efficiency both in terms of chemists' time and laboratory utility. Thus, our goal here was to carry out multiple sequential flow reactions in a fully automated fashion, allowing optimal use of laboratory facilities through 24/7 working.

Gilson Trilution LC and Unipoint software, while not specifically designed for conducting flow synthesis, allow the control and integration of various modular components. This enables the flexible construction of versatile flow platforms for automating complex multistep sequences. Using these software packages to control the readily assembled reactor shown in Fig. 7 and Scheme 4, the products in Table 2 were produced in a fully automated fashion. With the ability to program the filling of sample loops from a selection of reagents in an autosampler and to control switching multiple valves, it was possible to automate not only Steps 1 and 2 of a single reaction, but also to conduct multiple sequential reactions without manual intervention.⁷

In Step 1, Sample Loops A and B were loaded with starting materials from the autosampler, then switched into line and driven with a constant stream of MeCN by Pumps A and B. The starting materials mixed in a T-piece, and the combined flow stream was directed by Valve A through a CFC, followed by a scavenging column (selected by Valves B and C). The resulting azide intermediate then passed into the malononitrile reaction column, followed by a UV detector. The reactor output was directed to a collection flask by Valve D.

In Step 2, Sample Loop B was filled with a concentrated solution of malononitrile, and Valve A was switched to bypass the CFC and

scavenging column. Sample Loop B was switched into line, and Pumps A and B (1 : 9) were used to deliver a dilute wash solution of malononitrile into the system. This released any remaining triazole product from the reaction column, which exited through the UV detector and was collected into the same flask.

For each iterative reaction, Valves B and C were used to switch in a fresh scavenging column and Valve D to select a new collection flask. In this way, as many as six sequential reactions, corresponding to 55 continuous hours of reaction time, were easily performed by the automated reactor with no manual input required. The reaction sequence included two reaction steps, one purification step and one release step all carried out within a contained flow system, and provided the triazole products shown in Table 2 in good overall yields and purities following only evaporation of solvent and malononitrile.

While the general automated procedure shown in Scheme 4 provided access to useful quantities of triazole products in good overall yields and purities for a range of substrates, several reactions either proved unsuitable for flow processing due to low solubility of the products (Table 2, Entries 5, 8 and 10) or required slight modification of the general reaction procedure in order to obtain the desired triazoles in good yields and purities.

Under the general reaction conditions, 5-amino-1-(4-methoxyphenyl)-1*H*-1,2,3-triazole-4-carbonitrile was obtained in an overall isolated yield of only 10% (although still in $\geq 90\%$ purity as determined by ¹H NMR, Table 2, Entry 3a). Further investigation revealed that this low yield was due to decomposition of the 1-azido-4-methoxybenzene intermediate upon passage through the QP-SA portion of the scavenging column. This reaction was repeated with the scavenging column moved to after the malononitrile reaction column, which resulted in isolation of the triazole product in superior 73% yield and $\geq 90\%$ purity (Table 2, Entry 3b).

While early optimisation indicated that many azide intermediates required heating of the malononitrile column in order to achieve full conversion to the corresponding triazole products, the reaction of 1-azido-4-nitrobenzene was found to proceed with full conversion at room temperature. Reaction of this substrate at 60 °C, however, led to isolation of the desired triazole (26%)

STEP 1: React

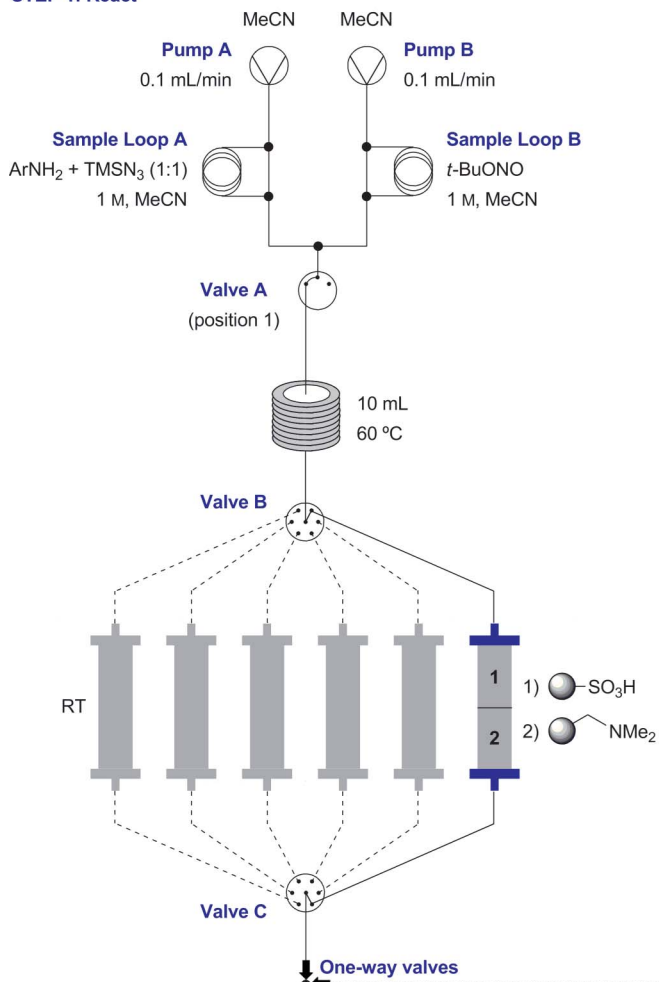

STEP 2: Release

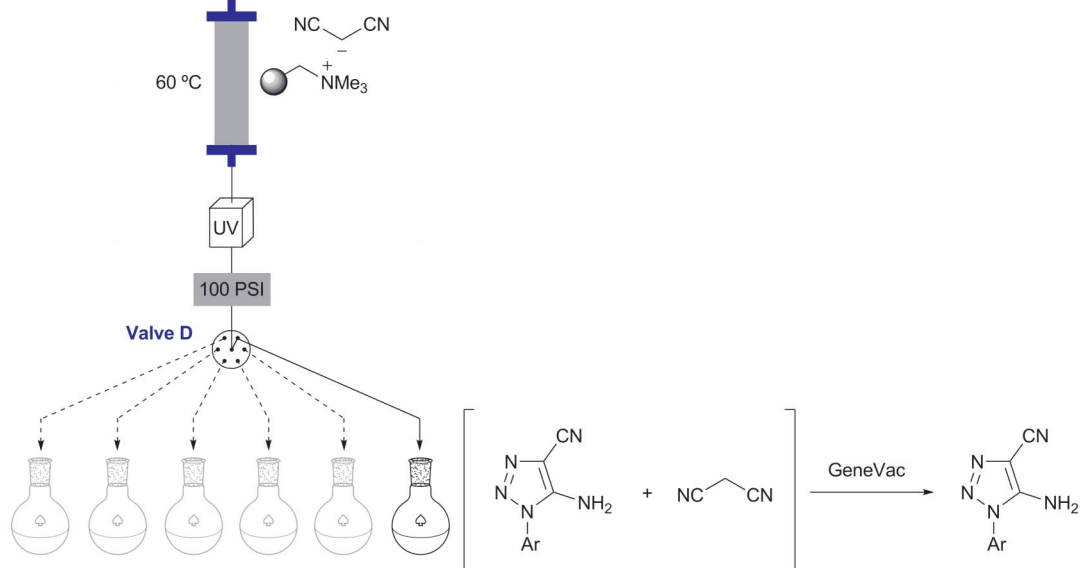
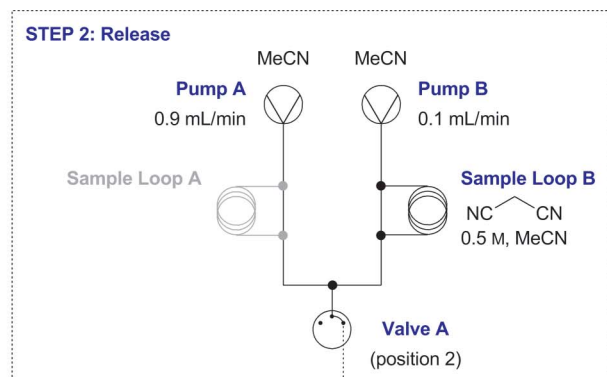

Scheme 4 Automated flow synthesis of 5-amino-4-cyano-1,2,3-triazoles. *Step 1:* Sample loops A and B are filled by the autosampler, then these starting materials injected and pumped through the system by Pumps A and B to effect azide generation, scavenging and triazole synthesis. *Step 2:* Sample loop B is filled by the autosampler with a concentrated solution of malononitrile (0.5 M), which is injected, diluted by Pump A and pumped through the system at 0.05 M. Valve A is now in position 2, allowing the wash solution to bypass the CFC and scavenging column to release the desired product from the malononitrile reaction column. Triazole products are collected, then purified by evaporation of malononitrile and MeCN in the GeneVac.



Fig. 7 Automated reactor for the flow synthesis of 5-amino-4-cyano-1,2,3-triazoles as depicted in Scheme 4.

contaminated with 4-nitroaniline (5%) (Table 2, Entry 4a), likely due to decomposition of 1-azido-4-nitrobenzene in the heated malononitrile column. Thus, for this substrate, the general reaction procedure was carried out with the malononitrile reaction column at ambient temperature, providing 5-amino-1-(4-nitrophenyl)-1*H*-1,2,3-triazole-4-carbonitrile in 87% yield and $\geq 95\%$ purity (Table 2, Entry 4b).

Given that the azide generation step proceeded with high conversion for all substrates examined (86–95%, see preceding publication, Table 1), the lower overall yields generally observed for triazole synthesis may indicate similar decomposition of other azide intermediates in the purification or reaction columns.

Finally, 5-amino-1-(2-iodophenyl)-1*H*-1,2,3-triazole-4-carbonitrile (Table 2, Entry 6) was found to be a low-melting solid and proved unsuitable for purification under the general evaporation conditions. Thus a scavenging process was developed in order to remove the excess malononitrile within the flow system.

Malononitrile could be successfully removed from the product stream by including a 15 mm i.d. glass column packed with 1,5,7-triazabicyclo[4.4.0]dec-5-ene polystyrene (PS-TBD, 11.25 g)¹⁵ be-

fore the exit of the flow system. This scavenging sequence was incorporated into the automated reaction process by extending the overall reaction time and incorporating a second set of column switching valves for the PS-TBD scavenging resin, making it possible to fully automate multiple sequential reactions. This PS-TBD scavenge step provided the desired triazole product completely free from malononitrile, but unfortunately in only approximately 80% purity as indicated by ¹H NMR. The significant impurities were acetamide and cyanoacetamide, along with two additional unidentified by-products, which were presumably formed by malononitrile and acetonitrile during the long residence time in the basic scavenging column. With the toxic malononitrile sequestered by this in-line scavenging process, these other impurities could be removed by column chromatography to provide the desired product in high purity and 55% yield (Table 2, Entry 6). Although this scavenging process allows successful removal of toxic malononitrile in this case, the expense of the PS-TBD reagent and the additional impurities generated during the scavenging step render the original evaporation protocol more attractive for general application.

Table 2 5-Amino-4-cyano-1,2,3-triazoles generated by the automated flow synthesis shown in Scheme 4

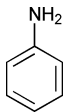
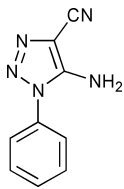
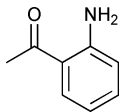
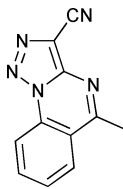
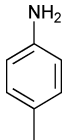
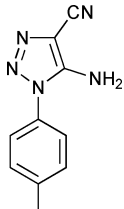
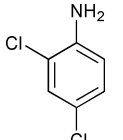
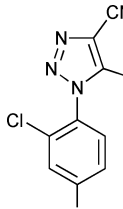
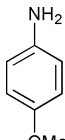
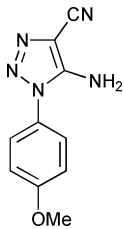
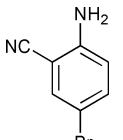
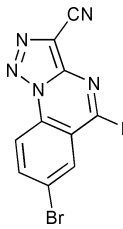
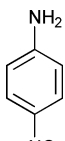
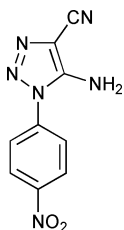
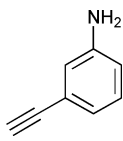
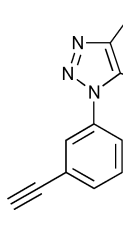
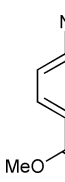
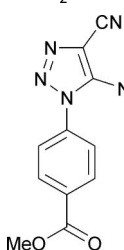
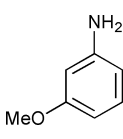
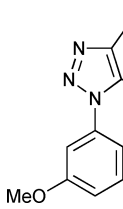
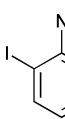
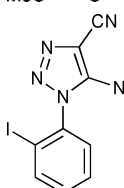
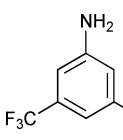
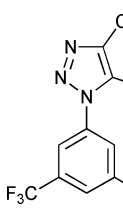
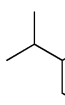
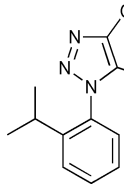
Entry	Aniline	Isolated product	Isolated yield ^a	Entry	Aniline	Isolated product	Isolated yield ^a
1			83%	8			N.Y. ^d
2			73%	9			53%
3			Standard: 10% Modified: 73% ^b	10			N.Y. ^d
4			Standard: 26% product + 5% aniline Modified: 87% ^c	11			60%
5			N.Y. ^d	12			76%
6			55% ^e	13			61%
7			85%				

^a All reactions on 1 mmol scale. ^b Modified procedure: The standard procedure was carried out with the scavenging column (2.6 g QP-SA + 2.6 g QP-DMA) located after the malononitrile reaction column. ^c Modified procedure: The standard procedure was carried out with the malononitrile column at room temperature. ^d N.Y. = no yield. The automated reactor shut down automatically mid-reaction, due to high system pressure caused by precipitate formation. The products shown were isolated: by flushing the system with acetonitrile (Entry 5), as the material collected in the output flask before reactor shutdown (Entry 8), or as crystalline solid recovered from the malononitrile reaction column (Entry 10). ^e This low-melting solid could not be purified by evaporation under the general conditions in the GeneVac. Instead, malononitrile was removed in-line with PS-TBD scavenger. The resulting crude product was contaminated with by-products from the scavenging process, which were removed by column chromatography.

Conclusions

The method described here for the flow synthesis and purification of aryl azides provides safe, scalable access to these versatile and important compounds. This general method can be used to provide a wide range of aryl azides in high conversions and purities, ready for isolation as final products or application in a variety of further transformations, such as the Staudinger reaction¹ or heterocycle formation.

The flow synthesis of 5-amino-4-cyano-1,2,3-triazoles involved four to five unit operations per reaction and accomplished the safe handling of toxic materials, unstable intermediates and hazardous reactions within a contained flow system, requiring only evaporation of solvent and malononitrile to furnish the desired products in high purity. As a result, a small library synthesis involving this complex multistep flow process was successfully carried out in a fully automated fashion, conducting up to six sequential reactions over 55 h with no manual intervention.

The development of improved technologies and techniques for flow processes and their automation is a significant challenge, but one which gives us increasing confidence that even longer, more challenging reaction sequences are possible. These techniques provide chemists with valuable tools with which to enhance productivity through an increased working schedule capable of a 24/7 operating regime.

Acknowledgements

We gratefully acknowledge Anachem Instruments Limited for assistance with Trilution LC software, Mark D. Hopkin for advice on automation, Mettler-Toledo AutoChem for assistance with the ReactIR, the Paul Mellon Fellowship (C. J. S.), the EPSRC (N. N. and H. L.), the Royal Society (I. R. B.) and the BP 1702 Fellowship (S. V. L.) for funding. We also wish to thank J. E. Davies for crystal structure determination and the EPSRC for a financial contribution toward the purchase of the X-ray diffractometer. We are grateful to the Department of Chemistry Photography Services for assistance with graphics.

Notes and references

- 1 C. J. Smith, C. D. Smith, N. Nikbin, S. V. Ley and I. R. Baxendale, *Org. Biomol. Chem.*, 2011, DOI: 10.1039/c0ob00813c.
- 2 S. Bräse, C. Gil, K. Knepper and V. Zimmermann, *Angew. Chem., Int. Ed.*, 2005, **44**, 5188–5240.
- 3 C. J. Smith, F. J. Iglesias-Siguenza, I. R. Baxendale and S. V. Ley, *Org. Biomol. Chem.*, 2007, **5**, 2758–2761.
- 4 V. Y. Rozhkov, L. V. Batog, E. K. Shevtsova and M. I. Struchkova, *Mendeleev Commun.*, 2004, **14**, 76–77; G. Biagi, I. Giorgi, O. Livi, A. Nardi and V. Scartoni, *J. Heterocycl. Chem.*, 2002, **39**, 1293–1298; G. L'Abbe and L. Beenaerts, *Bull. Soc. Chim. Belg.*, 1989, **98**, 421–422; A. Da Settimo, O. Livi, P. L. Ferrarini and G. Biagi, *Farmaco, Ed. Sci.*, 1980, **35**, 308–323; A. Da Settimo, O. Livi, P. L. Ferrarini, I. Tonetti and E. Ciabattini, *Farmaco, Ed. Sci.*, 1979, **34**, 371–382; A. Lucacchini,

- D. Segnini, A. Da Settimo and O. Livi, *Ital. J. Biochem.*, 1979, **28**, 194–206; D. R. Sutherland and G. Tennant, *J. Chem. Soc. C*, 1971, 706–713; A. Dornow and J. Helberg, *Chem. Ber.*, 1960, **93**, 2001–2010.
- 5 M. Baumann, I. R. Baxendale and S. V. Ley, *Mol. Diversity*, 2011, DOI: 10.3987/COM-10-S(E)77; J. Yoshida, *The Chemical Record*, 2010, **10**, 332–341; V. Hessel, *Chem. Eng. Technol.*, 2009, **32**, 1655–1681; *Microreactors in Organic Synthesis and Catalysis*, T. Wirth, ed., Wiley-VCH, Weinheim, 2008; N. Kockmann, M. Gottsponer, B. Zimmermann and D. Roberge, *Chem.–Eur. J.*, 2008, **14**, 7470–7477; B. P. Mason, K. E. Price, J. L. Steinbacher, A. R. Bogdan and D. T. McQuade, *Chem. Rev.*, 2007, **107**, 2300–2318; A. J. deMello, *Nature*, 2006, **442**, 394–402.
- 6 F. Venturoni, N. Nikbin, S. V. Ley and I. R. Baxendale, *Org. Biomol. Chem.*, 2010, **8**, 1798–1806; M. D. Hopkin, I. R. Baxendale and S. V. Ley, *Chem. Commun.*, 2010, **46**, 2450–2452; Z. Qian, I. R. Baxendale and S. V. Ley, *Synlett*, 2010, 505–508; I. R. Baxendale, J. Deeley, C. M. Griffiths-Jones, S. V. Ley, S. Saaby and G. K. Tranmer, *Chem. Commun.*, 2006, 2566–2568.
- 7 For examples of other automated sequences carried out using this software see: I. R. Baxendale, S. V. Ley, C. D. Smith, L. Tamborini and A.-F. Voica, *J. Comb. Chem.*, 2008, **10**, 851–857; C. M. Griffiths-Jones, M. D. Hopkin, D. Jönsson, S. V. Ley, D. J. Tapolczay, E. Vickerstaffe and M. Ladlow, *J. Comb. Chem.*, 2007, **9**, 422–430; M. Baumann, I. R. Baxendale, S. V. Ley, C. D. Smith and G. K. Tranmer, *Org. Lett.*, 2006, **8**, 5231–5234; I. R. Baxendale, C. M. Griffiths-Jones, S. V. Ley and G. K. Tranmer, *Synlett*, 2006, 427–430.
- 8 M. E. Kopach, M. M. Murray, T. M. Braden, M. E. Kobierski and O. L. Williams, *Org. Process Res. Dev.*, 2009, **13**, 152–160; F. Feigl and V. Anger, *Spot Tests in Inorganic Analysis*, trans. R. E. Oesper, Elsevier, Amsterdam, 6th English edn, 1972, p. 357.
- 9 J. Wiss, C. Fleury and U. Onken, *Org. Process Res. Dev.*, 2006, **10**, 349–353.
- 10 The ReactIR™ 45 m and iC IR™ software are available from Mettler-Toledo AutoChem, 7075 Samuel Morse Drive, Columbia, Maryland, USA. Website: www.mt.com.
- 11 H. Lange, C. F. Carter, M. D. Hopkin, A. Burke, J. G. Goode, I. R. Baxendale and S. V. Ley, *Chem. Sci.*, 2011, DOI: 10.1039/C0SC00603C; Z. Qian, I. R. Baxendale and S. V. Ley, *Chem.–Eur. J.*, 2010, **16**, 12342–12348; C. F. Carter, H. Lange, S. V. Ley, I. R. Baxendale, B. Wittkamp, J. G. Goode and N. L. Gaunt, *Org. Process Res. Dev.*, 2010, **14**, 393–404; C. F. Carter, I. R. Baxendale, M. O'Brien, J. B. J. Pavey and S. V. Ley, *Org. Biomol. Chem.*, 2009, **7**, 4594–4597.
- 12 All spectra shown here have had MeCN solvent background subtracted. See supplemental information for specific details about ReactIR monitoring.
- 13 Triazole products were only partially trapped on the reaction column, ruling out the possibility for a catch-and-release procedure. The extent of product trapping seemed to vary from substrate to substrate, presumably according to the pK_a of the free amine protons.
- 14 Reuse of the same malononitrile column for six sequential reactions resulted in minimal cross-contamination; each triazole product was found to contain ≤1% of each of the previous products by ¹H NMR. It was found that further washing with malononitrile did little to improve this cross-contamination. For the purposes of this study, it was determined to be acceptable to obtain products with traces of cross-contamination in favour of the process efficiency benefits of reusing malononitrile columns. If this degree of cross-contamination is unacceptable for a given library synthesis, it was found that cross-contamination could be completely eliminated by swapping in a fresh malononitrile column between sequential reactions.
- 15 PS-TBD resin from several sources was evaluated for use in this scavenging protocol. Performance was found to vary both in terms of purity of the isolated products and also in terms of backpressure characteristics for use in flow. PS-TBD from Biotage (part number 800321) was used for the work described here.